

EasyMove Straps

Conducting a thorough risk assessment is essential to ensuring the appropriate size, material and style of sling is used

HighStar's EasyMove strap system can be used to either extend a sling's existing straps, or to stabilize an actively moving client. It can be used as an accessory to any loop-style sling with head support. When attached to a sling's head support EasyMove's unique strap system counterbalances against a client who extends or moves while being transferred, encouraging the sling to move in concert with the client and accomplish a stable transfer.

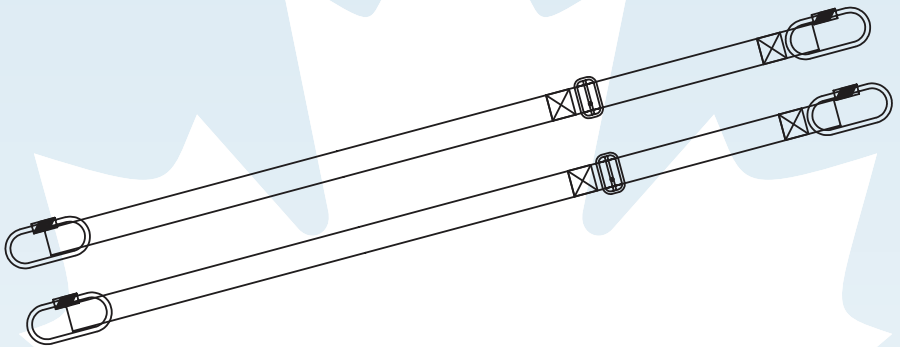

Washing Guidelines

- Remove carabiners from EasyMove prior to washing
- Wash inside a laundry bag for a longer-lasting EasyMove.
- Temperatures not to exceed 80°C/ 176°F
- Do not use bleach
- Air dry, or cool tumble dry. No heat.
- Do not dry clean
- Do not iron



General Guidelines

- Read and understand the instructions before use
- Always visually inspect the easy move before use, checking for tears, rips, or frays.
- Do not exceed the sling's weight capacity
- Check the sling's label is legible
- A properly cared for sling should approximately last 2-3 years

Remove from use if the EasyMove appears to be deteriorating

We recommend not to wash the EasyMove and instead disinfect it with an accelerated hydrogen peroxide when necessary



INSTRUCTIONS FOR SLING APPLICATION

Always check the appropriate sling style, material and size has been selected before applying the sling

- Apply the sling according to the relevant sling instructions.

If using EasyMove as a counterbalance strap for a sling with head support...

- Use EasyMove's carabiners to attach one end to the selected sling's head support straps. For optimal balance fasten each of EasyMove's straps to the same coloured loop.
- Next attach EasyMove's remaining carabiners to the sling's shoulder or hip strap. Use the same coloured loops for optimal balance.
- Note: It should not matter which loops are used. EasyMove is adjustable for optimal comfort.
- Tightly fasten EasyMove's carabiners.
- Apply all straps to the carry bar. When secure, raise the client.



If using as an extension strap loop on a sling...

- Using both carabiners attach one EasyMove strap to the leg, hip or shoulder strap to be extended. The EasyMove should now form a loop.
- Then fasten the EasyMove's carabiners to the same strap on the sling's opposite side. For optimal balance select the same strap and coloured loop.
- Adjust the EasyMove's length for optimal comfort.
- Apply all straps to the carry bar and ensure they are secure before raising the client.

- Before raising, each of the sling's loops must be securely fastened to the carry bar.