

DELUXE RECLINE SLING

Conducting a thorough risk assessment is essential to ensuring the appropriate size, material and style of sling is used

HighStar's full-body Deluxe Recline is the most comfortable sling of its type. Designed to eliminate pressure points, the sling's seamless body prevents uncomfortable creases from forming. The soft material sewn atop its connecting straps reduces skin irritation.

In either a seated or reclined position, the Deluxe Recline is specially designed for clients with amputations, clients with poor skin integrity or anyone in a sling for an extended period. Offered in spacer fabric and with or without head support, the Deluxe Recline is compatible with any floor or ceiling lift that accepts loop style slings.

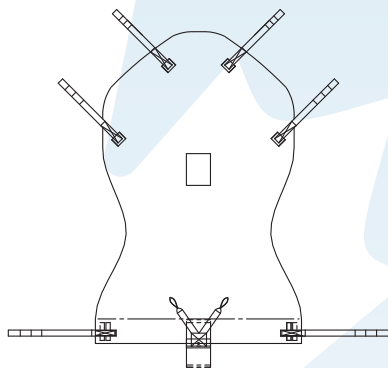
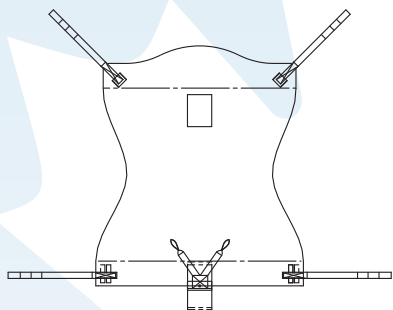

Washing Guidelines

- Wash inside a laundry bag for a longer-lasting sling
- Temperatures not to exceed 80°C/ 176°F
- Do not use bleach
- Air dry, or cool tumble dry. No heat.
- Do not dry clean
- Do not iron

Always check the product label for washing instructions.



General Guidelines

- Read and understand the instructions before use
- Always visually inspect the sling before use, checking for tears, rips, or frays.
- Do not exceed the sling's weight capacity
- Check the label is legible
- A properly cared for sling should approximately last 2-3 years

Remove from use if the sling appears to be deteriorating or if the label is no longer legible



INSTRUCTIONS FOR SLING APPLICATION

Always check the appropriate sling style, material and size has been selected before applying the sling

- Always ensure the sling's label is on the outside.
- The Deluxe Recline should only be applied to a client in a supine position.



When applying, align the sling's darts with the client's hips.

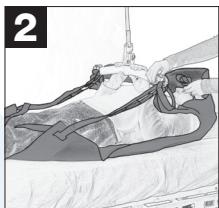

Feed the long leg straps through the middle leg separation straps' loop, as required.

Attach the strap loops to the lift's carry bar. For optimal balance during the transfer: apply the same coloured loops on each side.

In general, to achieve a 90° seated position, use short shoulder loops and longer leg loops.



Before raising, each of the sling's loops must be securely fastened to the carry bar. Check each loop.

- When not in use, the leg separation straps are easily stored in the velcro pouch at the sling's bottom.